

Designing the Purse

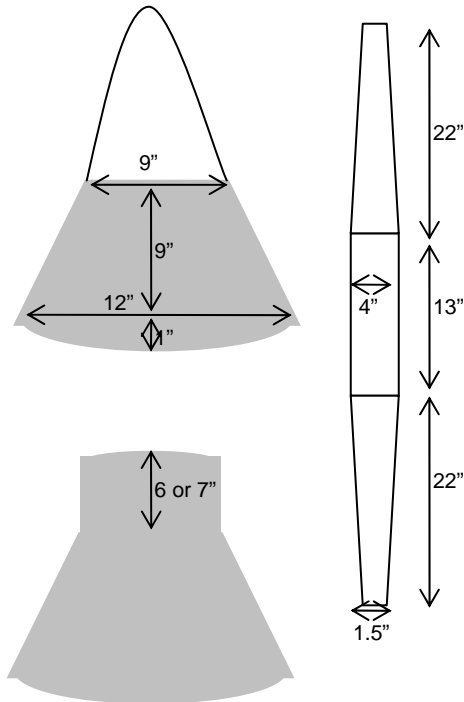

On the left is the shape of my purse. The long figure to the right is the bottom, sides, and strap of the purse, which will be knit in one piece and then connected together to form one large loop. The front and back of the purse will be knitted separately. Then, all three pieces will be connected to form the purse.

The back side of the purse will be knitted longer to provide a flap, so the purse can be closed.

My final measurements are also depicted.

Note: The arc at the bottom of the purse is 13" from end to end, and the handle will be approximately 24 inches in length when done.

Now, I have to figure out how large I have to make the purse to shrink to the final measurements.

Some of us are not mathematical geniuses, which means we need all the help we can get. If you fall into that category, you might want to draw out your design to the exact measurements on a piece of tissue paper. Newspaper also works well for this purpose. After you have drawn out each piece, cut it out. Having the actual pieces helps with measuring sections, such as triangles, arcs, etc... And having exact measurements will help with gauge and stitches per inch and all those figures that you absolutely hate to deal with. Unfortunately, if you want your item to come out right, you have to do this. If you don't mind experimenting, then go for it and guess!!! – This one is only a purse, so it does not matter too much!

I intend to knit the entire purse in garter stitch, so I will use the gauge and the shrinkage from the garter stitch swatch.

Gauge = 4 sts & 8 rows per inch

Shrinkage = 32% in the Width & 20% in the Length

I will now dissect the pieces of the purse to determine how large I need to knit each section in order to achieve the final measurements.

Section	Width or Length Measurement	Final Measurement	Measurement Increased by Percentage	Stitches / Rows to Knit
Bottom Section of Strap	W (32% Loss)	4"	5.25"	21-22 Sts
	L (20% Loss)	13"	15.5"	104 Rows
One Side of Strap	W at Top	1.5"	2"	8 Sts
	W at Bottom	4"	5.25"	21-22 Sts
	L	22	26.5"	212 Rows
One Side of Purse	W at Top	9"	12"	48 Sts
	W at Bottom	12"	16"	64 Sts
	Curve at Bottom	13"	17"	68 Sts
Note: Flap is only on one side	Length (w/o curve)	9"	11"	88 Rows
	Curve Length	1"	1"	8 Rows
	Flap Length	6-7"	7 - 8"	56 – 64 Rows

Now, I should be able to create my pattern:

Strap: Using an invisible or crochet cast on = CO 8 sts

Row 1: Sl 1st st, Knit across, turn

Repeat Row 1 for 28 more rows, then do an increase row as follows:

Increase Row: Sl 1st st, K1, M1, knit across to last two stitches, M1, K to end, turn

Repeat Row 1 for 29 rows, then do Increase Row - Repeat from * to * until piece measures 26 ½ " and you have 22 sts

Repeat Row 1 until piece measures 42"

Now you will begin decreasing.

Decrease Row: Sl 1st st, K2tog, knit to the last three stitches, K2tog, k1, turn

Knit even for the next 29 rows, then do a decrease row -- Repeat from * to * until piece is a total of 68.5" in length and you have 8 sts left on needle.

Kitchener stitch the cast on beginning to end, and weave in tails.

Piece one is complete. -- Stand by for Part three!